

# HLB 槓桿油壓缸 FCM法蘭型油路板附調速

Flange type manifold with flow control



## Hydraulic lever-type Cylinder

• Bore:  $\phi 25$ - $\phi 40$ mm • Pmax: 140kg/cm<sup>2</sup>

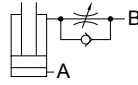
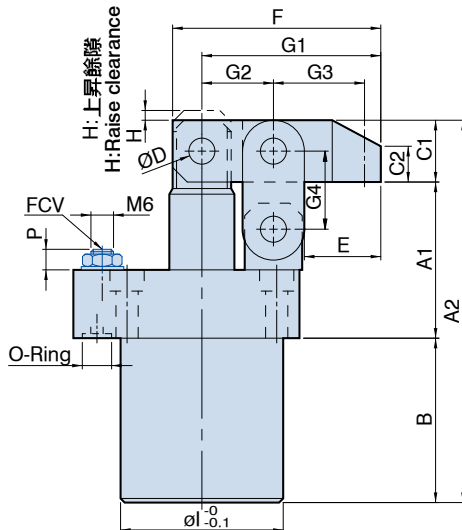
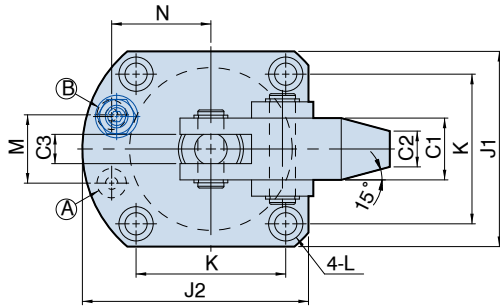

- Ⓐ 夾持油孔  
Clamping Port
- Ⓑ 放鬆油孔  
Unclamping Port



HLB-FCM Bore -L

HLB-FCM Bore -R

### Dimensional table

UNIT:mm

ITEM	MODEL	HLB-FCM25	HLB-FCM32	HLB-FCM40
A1		49	52	57
A2		122	129	146.2
B		54	56	67
C1		□19	□21	□22.2
C2		11	12	13
C3		9	9	10
øD		ø8	ø9	ø10
E		24	25	29
F		64	66.5	77
G1		55	57	66
G2		22	22	26
G3		28	29.5	34
G4		24	25	29
H		3	3	4
øI		ø45	ø50	ø58
J1		56	60	70
J2		65	69.5	81
K		43	47	53
L		ø6.8-ø10.5x6.5D.	ø6.8-ø10.5x6.5D.	ø9-ø14x9D.
M		20	21	27
N		28	30.5	35
O-Ring		P7	P7	P9
P Min.		7.1	4.1	4.1
P Max.		10.2	8.1	8.1